

Characteristics

At a glance

Further information → [ysr-c](#)

- Hydraulic shock absorber
- Rapidly increasing cushioning force curve
- Short cushioning stroke
- Suitable for rotary drives
- Maintenance-free
- Through mounting thread

Diagrams

Further information → [ysr-c](#)

The diagrams shown in this document are also available online. These can be used to display precise values.

Cushioning

[C] Self-regulating

Path-controlled flow control function

Type code

001	Series
YSR	Shock absorber

002	Size
4	4 mm
5	5 mm
7	7 mm
8	8 mm
10	10 mm
12	12 mm
16	16 mm
20	20 mm
25	25 mm
32	32 mm

003	Stroke [mm]
4	4
5	5
8	8
10	10
12	12
20	20
25	25
40	40
60	60

004	Cushioning
C	Self-regulating

Datasheet

General technical data

Size	4	5	7	8	10	12	16	20	25	32
Stroke	4 mm	5 mm		8 mm	10 mm	12 mm	20 mm	25 mm	40 mm	60 mm
Mode of operation	Single-acting, Pushing									
Cushioning	Self-adjusting									
Cushioning length	4 mm	5 mm		8 mm	10 mm	12 mm	20 mm	25 mm	40 mm	60 mm
Type of mounting	Via lock nut									
Max. impact speed	2 m/s		3 m/s							
Mounting position	optional									
Ambient temperature	-10 ... 80°C									
Corrosion resistance class CRC ¹⁾	2 - Moderate corrosion stress									

1) More information www.festo.com/x/topic/crc

Reset time

Size	4	5	7	8	10	12	16	20	25	32
Reset time at room temperature ¹⁾	0.2 s						0.3 s		0.4 s	0.5 s

1) At higher temperatures (+80 °C) the max. mass and the cushioning energy must be reduced by approx. 50%.
At low temperatures (-10 °C), the reset time may be up to 1 second.

Forces

Size	4	5	7	8	10	12	16	20	25	32
Min. insertion force ¹⁾	6.5 N	7.5 N	10 N	18 N	25 N	35 N	60 N	100 N	140 N	160 N
Max. stop force ²⁾	100 N	200 N	300 N	500 N	700 N	1,000 N	2,000 N	3,000 N	4,000 N	6,000 N
Reset force ³⁾	0.7 N	0.9 N	1.2 N	2.5 N	3.5 N	5 N	6 N	10 N	14 N	20 N

1) This is the minimum force that must be applied so that the shock absorber is pushed precisely into the retracted end position. This value is reduced accordingly with an extended external end position.

2) If the max. stop force is exceeded, a fixed stop (e.g. YSRA) must be fitted 0.5 mm before the end of the stroke.

3) This is the maximum force that can act on the piston rod so that the shock absorber still extends completely (e.g. upstream bolt).

Energy

Size	4	5	7	8	10	12	16	20	25	32
Max. energy consumption per stroke	0.6 J	1 J	2 J	3 J	6 J	10 J	30 J	60 J	160 J	380 J
Max. energy consumption per hour	5,600 J	8,000 J	12,000 J	18,000 J	26,000 J	36,000 J	64,000 J	92,000 J	150,000 J	220,000 J
Max. residual energy	0.006 J	0.01 J		0.02 J	0.03 J	0.05 J	0.16 J	0.32 J	0.8 J	2 J

Mass range

Size	4	5	7	8	10	12	16	20	25	32
Mass range	1.2 kg	1.5 kg	5 kg	15 kg	25 kg	45 kg	90 kg	120 kg	200 kg	400 kg

Weight

Size	4	5	7	8	10	12	16	20	25	32
Product weight	5 g	8 g	16 g	32 g	51 g	74 g	185 g	318 g	600 g	1,220 g

Materials

Size	4	5	7	8	10	12	16	20	25	32
Material housing	High-alloy steel				Galvanised steel					
Material piston rod	High-alloy steel									
Material seals	NBR									
Note on materials	RoHS-compliant									
LABS (PWIS) conformity	VDMA24364-B2-L									

Datasheet

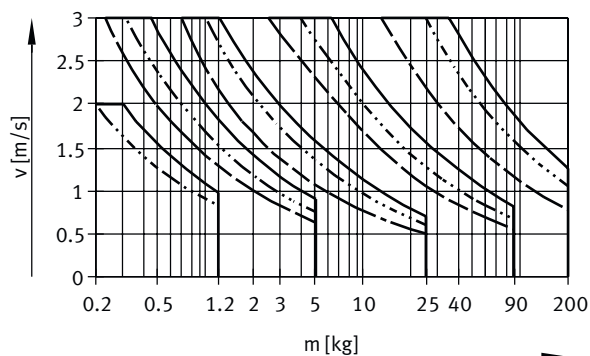
Impact velocity v as a function of mass m – YSR-4/7/10/16/25-C

- YSR-4-4-C = 0 N
- - - YSR-4-4-C = 50 N
- YSR-7-5-C = 0 N
- - - YSR-7-5-C = 100 N
- YSR-7-5-C = 200 N
- YSR-10-10-C = 0 N
- - - YSR-10-10-C = 150 N
- YSR-10-10-C = 300 N
- YSR-16-20-C A = 0 N
- - - YSR-16-20-C = 500 N
- YSR-16-20 = 800 N
- YSR-25-40-C = 0 N
- - - YSR-25-40-C = 1200 N
- YSR-25-40-C = 2500 N

Three force curves are shown for each shock absorber. Intermediate values must be averaged.

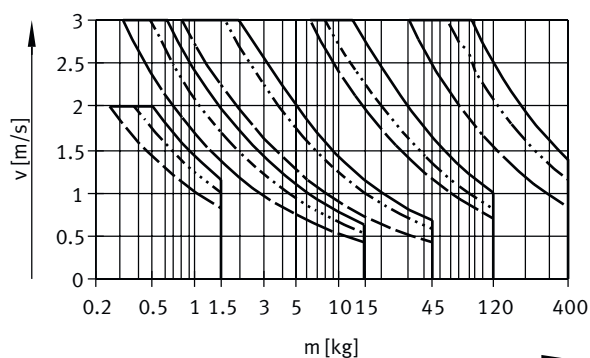
Impact velocity v as a function of mass m – YSR-5/8/12/20/32-C

- YSR-5-5-C 0 N
- - - YSR-5-5-C = 50 N
- YSR-5-5-C = 100 N
- YSR-8-8-C = 0 N
- - - YSR-8-8-C = 100 N
- YSR-8-8-C = 200 N
- YSR-12-12-C = 0 N
- - - YSR-12-12-C = 200 N
- YSR-12-12-C = 500 N
- YSR-20-25-C = 0 N
- - - YSR-20-25-C = 800 N
- YSR-20-25-C = 1200 N
- YSR-32-60-C = 0 N
- - - YSR-32-60-C = 2000 N
- YSR-32-60-C = 4000 N

Three force curves are shown for each shock absorber. Intermediate values must be averaged.

Dimensions

Dimensions – Shock absorber YSR...-C

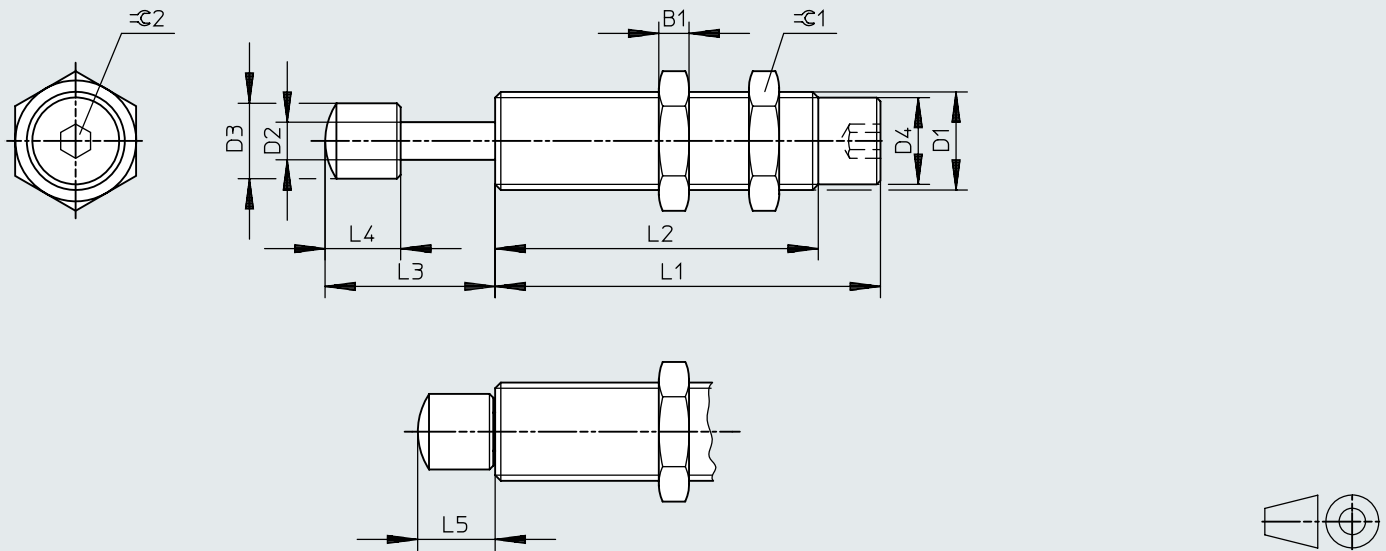
Download CAD data → www.festo.com

[1] To increase the service life: prevent dirt or liquids getting into the inner piston chamber via the piston rod (e.g. by using a cover).

	B1	D1	D2 ∅	D3 ∅	D4 ∅	L1 ±0,1	L2 ±0,3	L3	L4	L5	$\varnothing 1$	$\varnothing 2$
YSR-4-4-C	2,5	M6x0,5	2	3,5 ±0,05	5,3 ±0,05	28,5	18,5	8,3 +0,6/-0,3	4 ±0,1	4,3 +0,35/-0,25	8	2
YSR-5-5-C	3	M8x1	2,5	4,7 ±0,05	6,7 ±0,05	29	19	10,8 +0,6/-0,3	5,5 ±0,1	5,8 +0,55/-0,25	10	-
YSR-7-5-C	3,5	M10x1	3	6 ±0,1	8,6 ±0,05	34	23	12,3 +0,7/-0,35	7 ±0,2	7,3 +0,55/-0,25	13	
YSR-8-8-C	4	M12x1	4	8 ±0,2	10,4 ±0,1	46	33	16,3 +0,7/-0,35	8 ±0,2	8,3 +0,55/-0,25	15	
YSR-10-10-C	5	M14x1	5	10 ±0,2	12,4 ±0,1	55	42	20,5 +0,7/-0,35	10 ±0,2	10,5 +0,55/-0,25	17	
YSR-12-12-C	5	M16x1	6	12 ±0,2	14,5 ±0,1	64	51	24,5 +0,7/-0,35	12 ±0,2	12,5 +0,55/-0,25	19	
YSR-16-20-C	6	M22x1,5	8	16 ±0,2	19,6 ±0,1	86	69	36,5 +0,7/-0,35	16 ±0,2	16,5 +0,55/-0,25	27	
YSR-20-25-C	8	M26x1,5	10	20 ±0,2	23,8 ±0,1	104	87	45,5 +0,7/-0,35	20 ±0,2	20,5 +0,55/-0,25	32	
YSR-25-40-C	10	M30x1,5	12	25 ±0,2	27,8 ±0,1	152	125	61,5 +1,25/-0,75	20,5 ±0,4	21,5 +0,95/-0,55	36	
YSR-32-60-C	12	M37x1,5	15	32 ±0,2	34,8 ±0,1	205	179	87 +1,25/-0,75	26 ±0,4	27 +0,95/-0,55	46	

Dimensions

Dimensions – Mounting flange YSRF

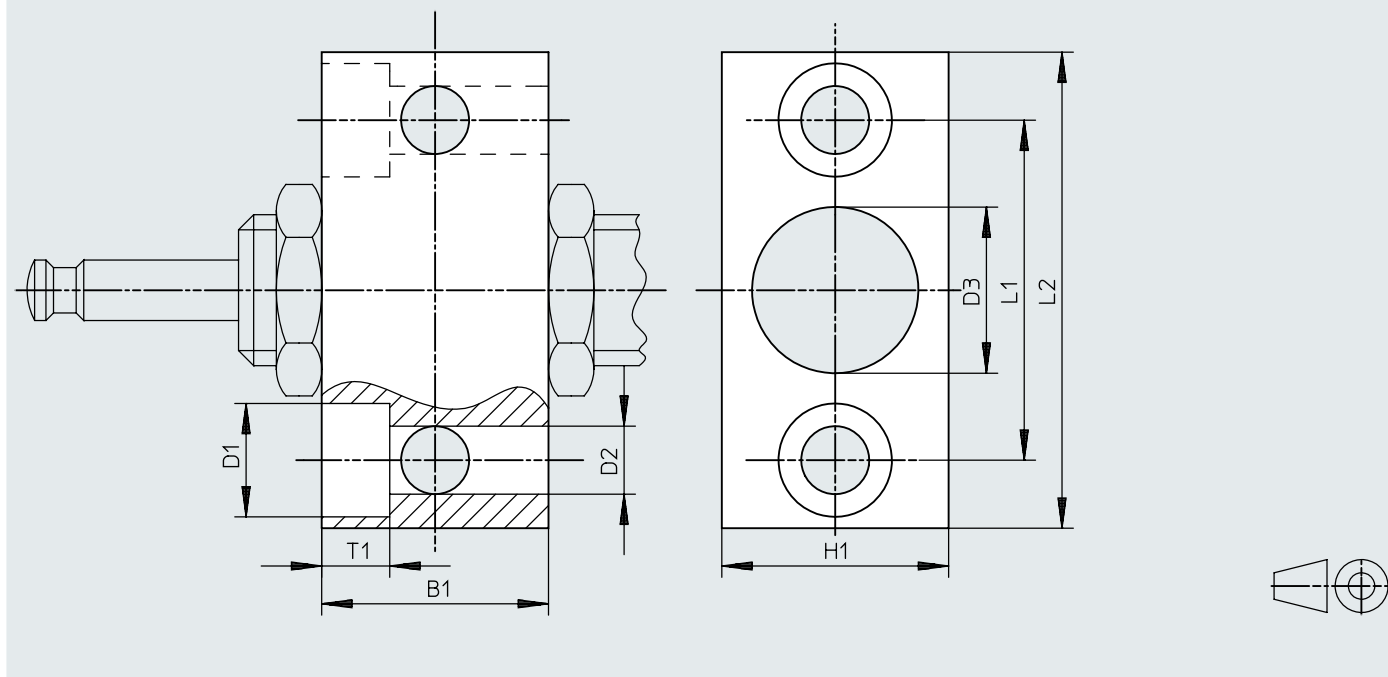
Download CAD data → www.festo.com

	B1	B2	D1	D2	D3	H1	L1	L2
YSRF-8 ¹⁾	16	5,5	10	5,5	10,2	16	25	38
YSRF-25	45	13	20	13,5	30,2	45	63	86
YSRF-32	55	15	24	15,5	37,2	55	80	108

1) For shock absorber diameter size 7

Dimensions

Dimensions – Mounting flange YSRF-...-C

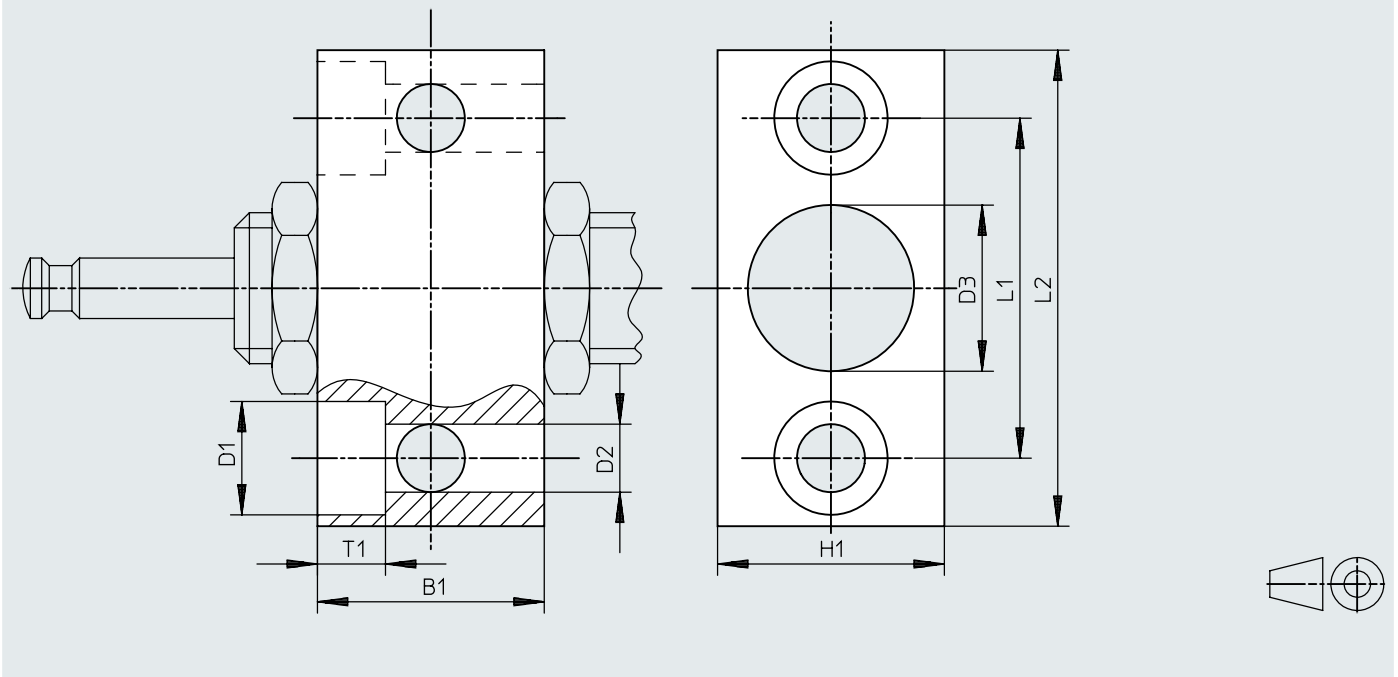
Download CAD data → www.festo.com

	B1	B2	D1	D2	D3	H1	L1	L2
YSRF-8-C	20	5,5	10	5,5	12,2	20	28	41
YSRF-12-C	25	6,8	11	6,6	16,2	25	36	50
YSRF-16-C	32	9	15	9	22,2	32	45	63
YSRF-20-C	40	11	18	11	26,2	40	56	78

Dimensions

Dimensions – Mounting flange YSRF-S-...-C

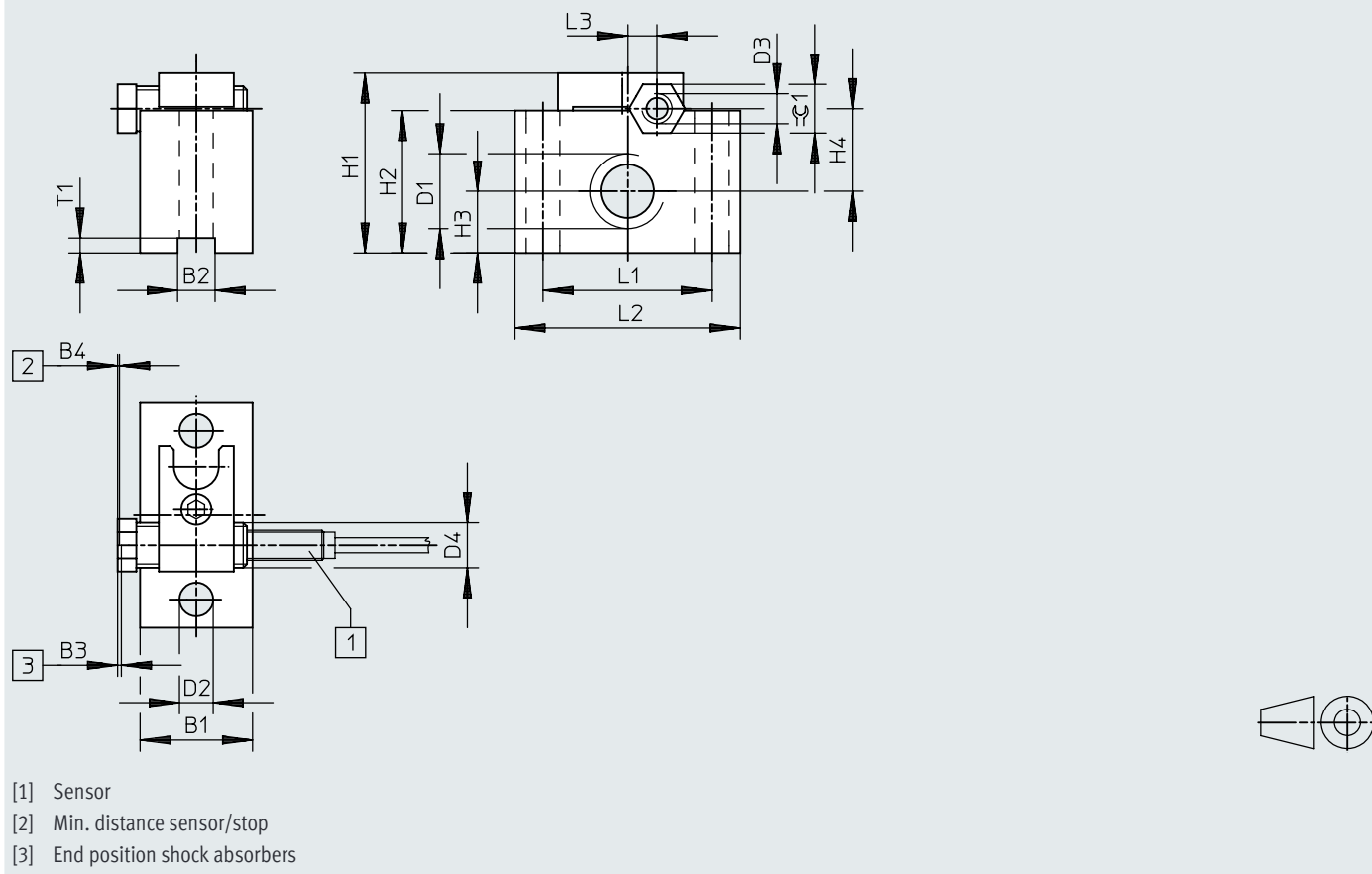
Download CAD data → www.festo.com

	B1	D1	D2 ∅	H1	H2	H3	H4	L1	L2	L3	T1
YSRF-S-8-C	20	M12x1	5,5	35	25	9,5	16	32	45	4	2
YSRF-S-12-C	25	M16x1	6,6	42	32	12,5	20	36	50	3	4
YSRF-S-16-C	30	M22x1,5	9	48	38	16,5	22	45	60	8	4
YSRF-S-20-C	30	M26x1,5	11	52	42	19	23,5	56	80	11,5	4

Dimensions

Dimensions – End stop limiter YSRA-...-C

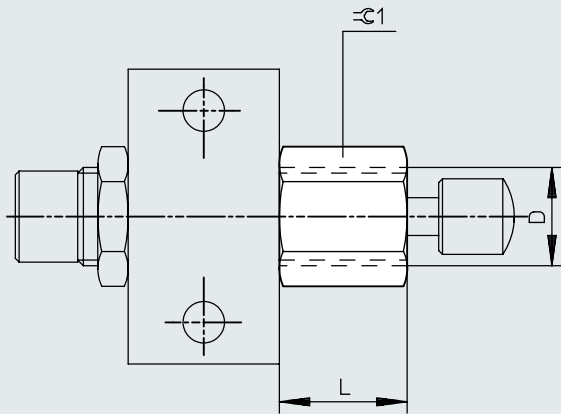
Download CAD data → www.festo.com

	D	L	e
YSRA-7-C	M10x1	14,5	13
YSRA-8-C	M12x1	18	15
YSRA-12-C	M16x1	24,5	19

Ordering data

Ordering data					
	Size	Stroke	Cushioning	Part no.	Type
	4	4 mm	Self-adjusting	540060	YSR-4-4-C
	5	5 mm		158981	YSR-5-5-C
	7			160272	YSR-7-5-C
	8	8 mm		34571	YSR-8-8-C
	10	10 mm		191199	YSR-10-10-C
	12	12 mm		34572	YSR-12-12-C
	16	20 mm		34573	YSR-16-20-C
	20	25 mm		34574	YSR-20-25-C
	25	40 mm		160273	YSR-25-40-C
	32	60 mm		160274	YSR-32-60-C

Peripherals

Peripherals overview YSR-...-C

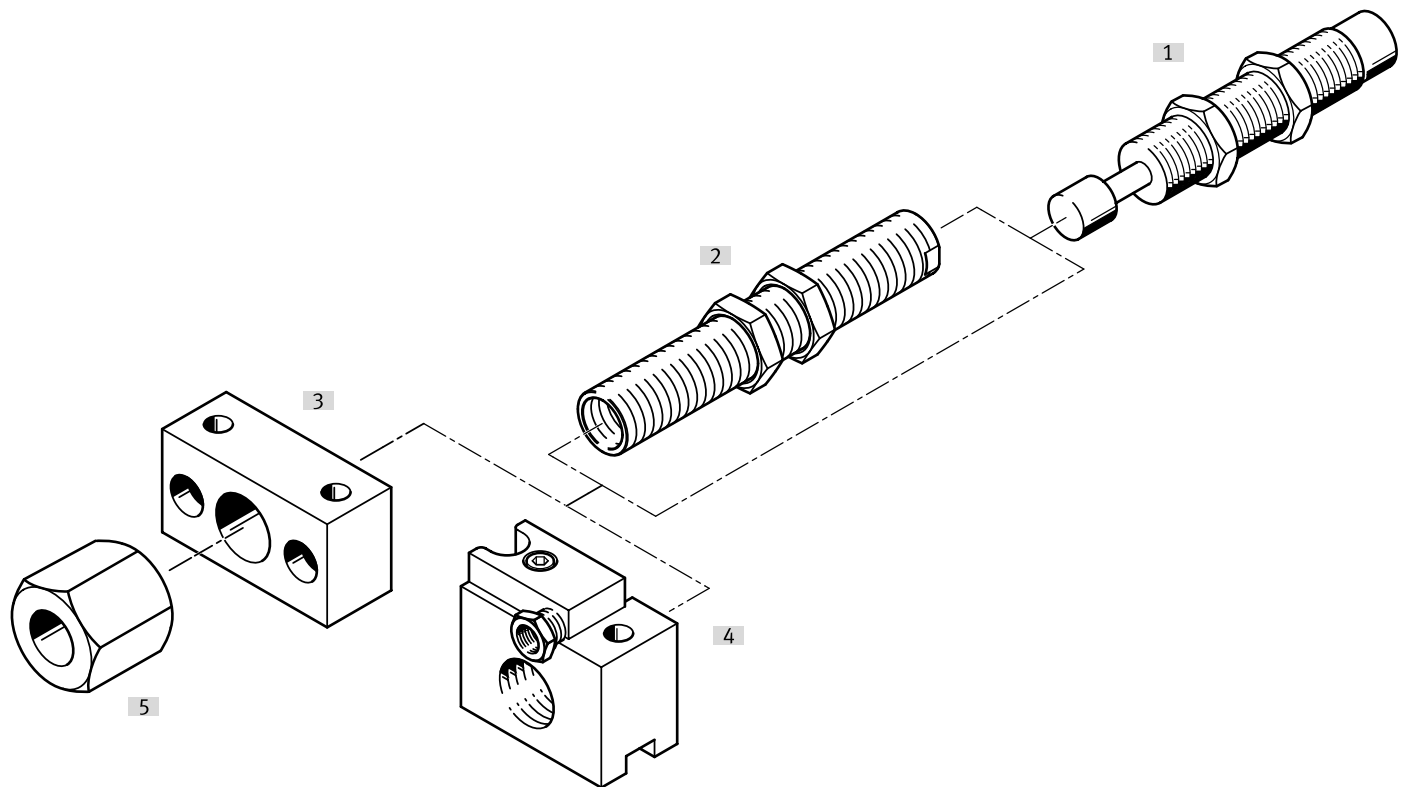

Accessories			→ Page/Internet
Type/order code	Description		
[1] Shock absorber YSR-...-C	Hydraulic shock absorber with rapidly increasing cushioning curve		ysr-c
[2] Reducing sleeve DAYH	In order to improve the cushioning characteristics with smaller loads, the installed shock absorber can be replaced by the next smaller shock absorber with the help of the reducing sleeve.		14
[3] Mounting flange YSRF	Mounting option for shock absorber		13
[4] Mounting flange YSRF-S	Mounting option for shock absorber with integrated, attached stop sleeve and position detection		13
[5] End stop limiter YSRA	Stroke limitation for shock absorber		14
[6] Proximity switch SIEN	For mounting flange YSRF-S		13

Accessories

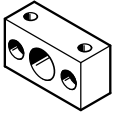
Mounting flange YSRF					
	Size ¹⁾	Material housing	Product weight	Part no.	Type
	8	Steel, Galvanised	50 g	11681	YSRF-8
	25		895 g	11685	YSRF-25
	32		1,730 g	11686	YSRF-32

1) YSRF-8 for shock absorber size 7

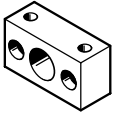
Mounting flange YSRF-C					
	Size ¹⁾	Material housing	Product weight	Part no.	Type
	8	Steel, Galvanised	90 g	34575	YSRF-8-C
	12		180 g	34576	YSRF-12-C
	16		330 g	34577	YSRF-16-C
	20		700 g	34578	YSRF-20-C

1) YSRF-8 for shock absorber size 7

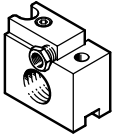
Mounting flange YSRF-S-...-C					
	Size	Material housing	Product weight	Part no.	Type
	8	Steel, Galvanised	12 g	34579	YSRF-S-8-C
	12		130 g	34580	YSRF-S-12-C
	16		180 g	34581	YSRF-S-16-C
	20		250 g	34582	YSRF-S-20-C

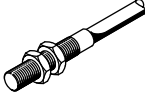
Proximity switch SIEN for mounting flange YSRF-S-...-C						
	Type of mounting	Switching element function	Switching output	Electrical connection	Part no.	Type
	Via lock nut	N/C contact	PNP	Open end	150390	SIEN-M8B-PO-K-L
				Plug M8, A-coded	150391	SIEN-M8B-PO-S-L
		N/O contact		Open end	150386	SIEN-M8B-PS-K-L
				Plug M8, A-coded	150387	SIEN-M8B-PS-S-L

Connecting cables NEBU, straight						
	Electrical connection 1, connector system	Electrical connection 2, connector system	Electrical connection 2, number of connections/cores	Cable length	Part no.	Type
	M8x1, A-coded, to EN 61076-2-104	Open end	3	2.5 m	541333	NEBU-M8G3-K-2.5-LE3
				5 m	541334	NEBU-M8G3-K-5-LE3

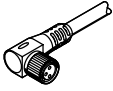
Connecting cables NEBU, angled						
	Electrical connection 1, connector system	Electrical connection 2, connector system	Electrical connection 2, number of connections/cores	Cable length	Part no.	Type
	M8x1, A-coded, to EN 61076-2-104	Open end	3	2.5 m	541338	NEBU-M8W3-K-2.5-LE3
				5 m	541341	NEBU-M8W3-K-5-LE3

Accessories

End stop limiter YSRA-...-C					
	Size	Material housing	Product weight	Part no.	Type
	7	Steel, Galvanised	12 g	150932	YSRA-7-C
	8		28 g	150933	YSRA-8-C
	12		48 g	150934	YSRA-12-C

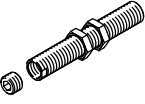
Reducing sleeve DAYH					
	Type of mounting	Material stops	Product weight	Part no.	Type
	Via lock nut	High-alloy stainless steel	11.5 g	1165476	DAYH-4